

Quiet-Zone Bathroom Vent Fans

From Acme Miami by Sterling
Low Sones in the Quiet Zone
High Performance and High Energy Efficiency

The Quiet Zone Bathroom Fans feature a ball bearing Permanent Split Capacitor (PSC) motor with an aerodynamic blower wheel. And, an attractive, sleek flush grille. Lower RPM's for Lower Sones.

Model	Air Volume	Noise Level	Power Usage
QZ-80	80 CFM	0.3 Sones	25 watts
QZ-110	110 CFM	0.6 Sones	35 watts
LK-1	Light Kit includes 23 watt fluorescent bulb and night light.		



Housing

- Rugged corrosion resistant 26 gauge galvanized steel.
- Detachable 4" duct collar with built-in draft damper.
- Adjustable double hanger mounting brackets. Up to 24 inches for ideal positioning.

Motor

- Plug in permanently lubricated motor engineered for continuous operation.
- Exceeds Energy Star parameters. Ball bearings are standard. Permanent Split capacitor (PSC) motor with automatic thermal overload. 110 volts 60hz
- ETL and cETL listed for tub/shower when used with GFCI branch circuit.



Energy Star and HVI Certified and ETL Listed
Confirms to UL and cUL safety standards



www.acmemiami.com 1290 NW 74 Street, Miami, Florida 33147
1-800-654-2154 Fax: 1-305-693-0045 acmemiami3@earthlink.net

Quiet-Zone Fans

Models QZ-80 and QZ-110

Model Number	QZ-80		QZ-110	
Static Pressure in inches w.g.	0.1	0.25	0.1	0.25
Air Volume (CFM)	80	65	110	87
Noise (sones)	0.3	N/A	0.6	N/A
Fan Watts	25W		35W	
Duct Diameter	4"			
Power Rating (V/Hz)	120/60			

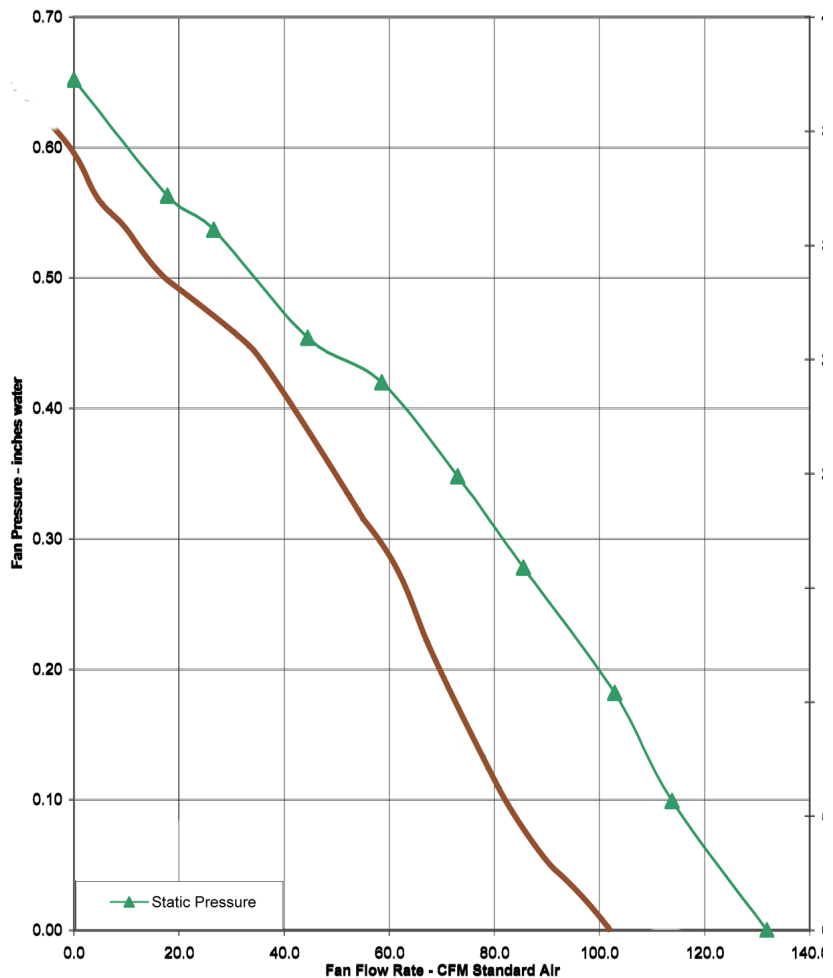
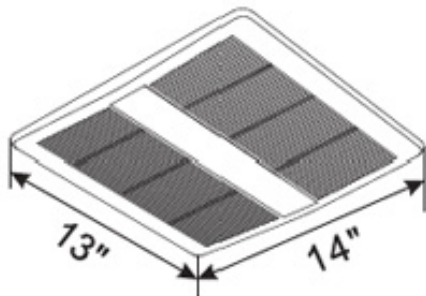
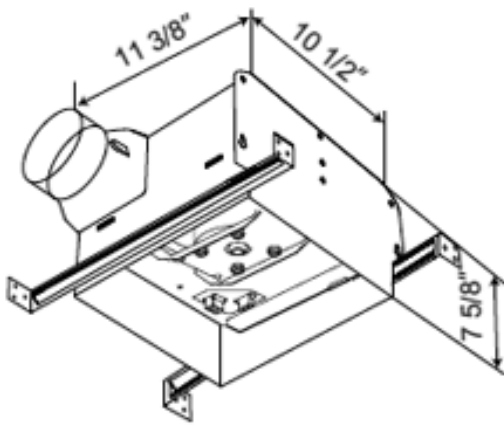

CERTIFICATIONS

